



US 20130026533A1

(19) **United States**

(12) **Patent Application Publication**
Lee

(10) **Pub. No.: US 2013/0026533 A1**

(43) **Pub. Date: Jan. 31, 2013**

(54) **ORGANIC LIGHT-EMITTING DIODE
DISPLAY AND MANUFACTURING METHOD
THEREOF**

(52) **U.S. Cl. 257/100; 438/26; 257/40; 257/E51.018**

(76) **Inventor: Jae-Ho Lee, Yongin-city (KR)**

(57) **ABSTRACT**

(21) **Appl. No.: 13/439,746**

(22) **Filed: Apr. 4, 2012**

(30) **Foreign Application Priority Data**

Jul. 29, 2011 (KR) 10-2011-0076032

Publication Classification

(51) **Int. Cl.**

H01L 51/52 (2006.01)

H01L 51/56 (2006.01)

An organic light emitting diode display includes a substrate, an organic light emitting diode on the substrate, an organic film configured to cover the organic light emitting diode on the substrate in an organic film deposition area having a first diameter, and an inorganic film configured to cover the organic film on the substrate in an inorganic film deposition area having a second diameter, wherein L1 is the first diameter of the organic film deposition area in μm , wherein L2 is the second diameter of the inorganic film deposition area in μm , wherein D is a thickness of the organic film in μm , and wherein $L2-L1 \geq 2(171D+150 \mu\text{m})$.

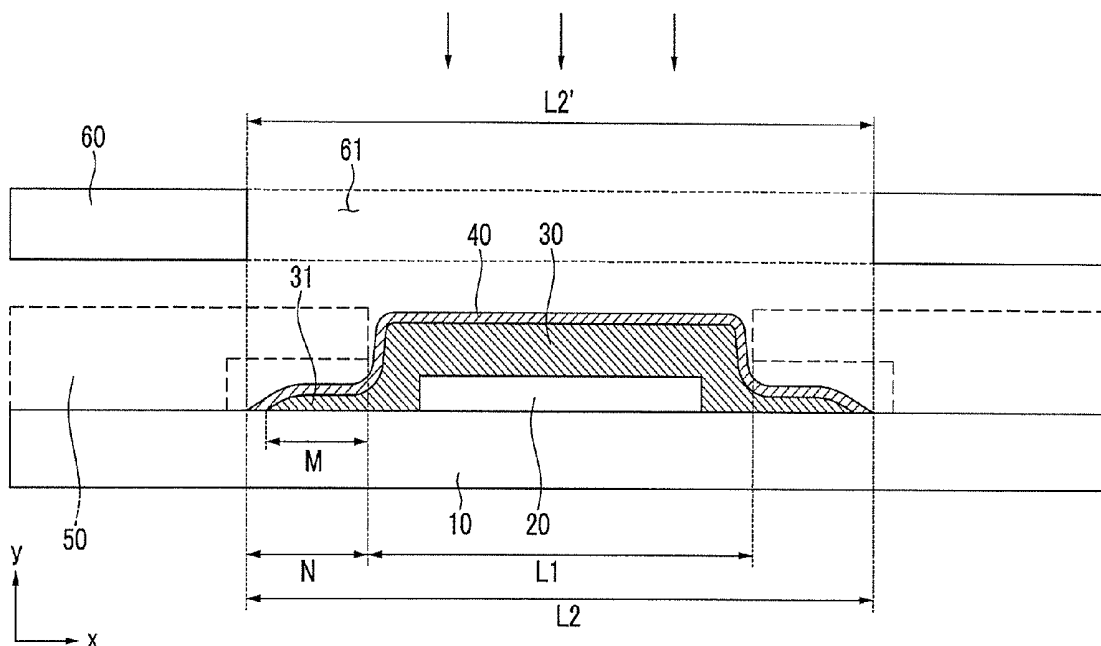

FIG.1

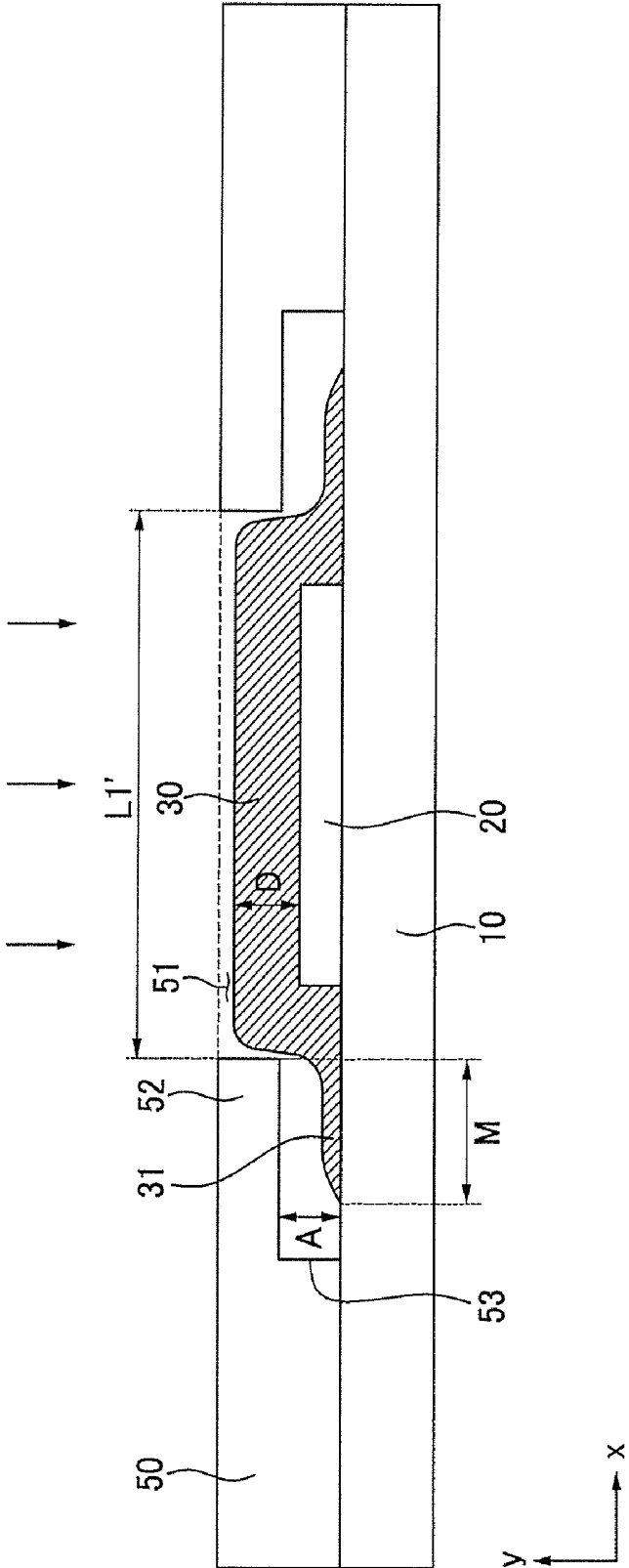

FIG.2

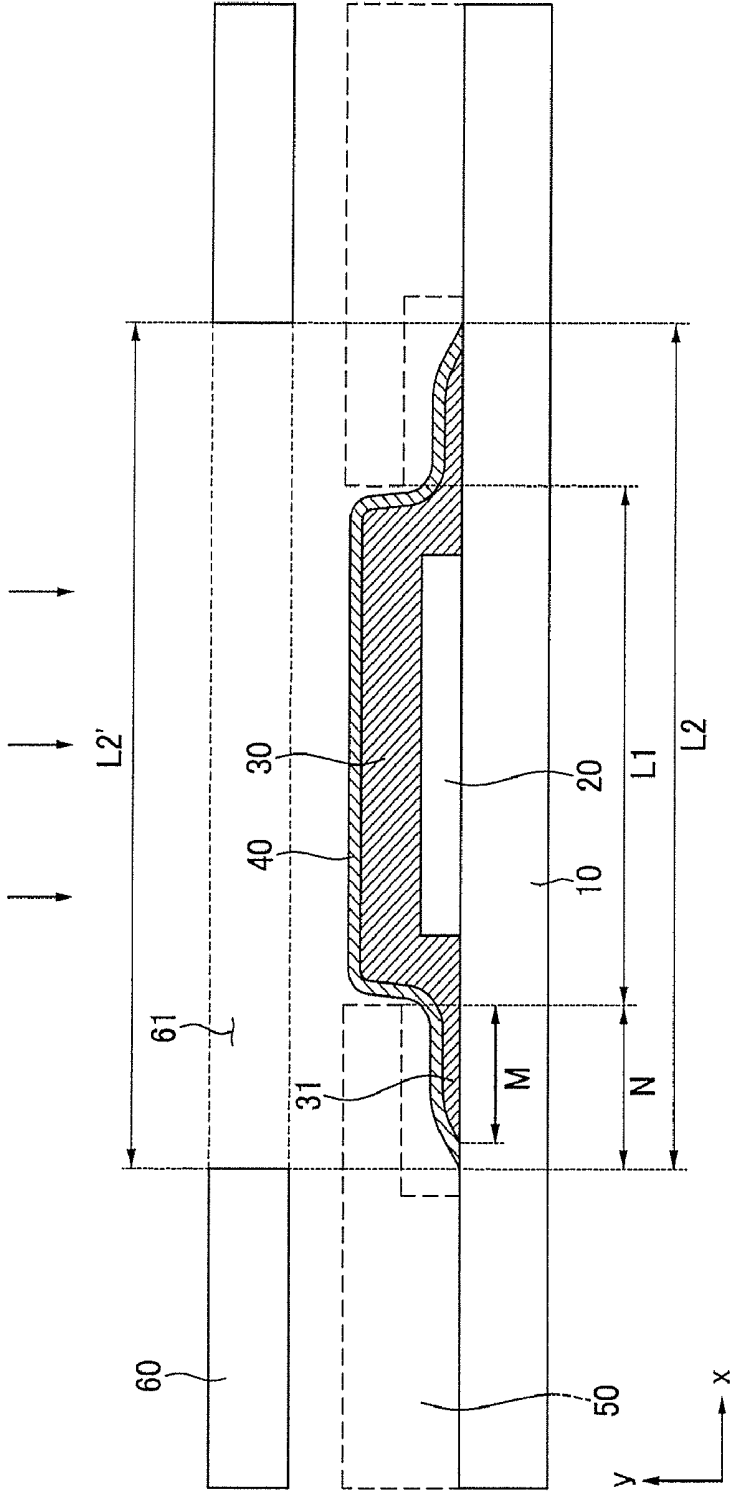

FIG.3

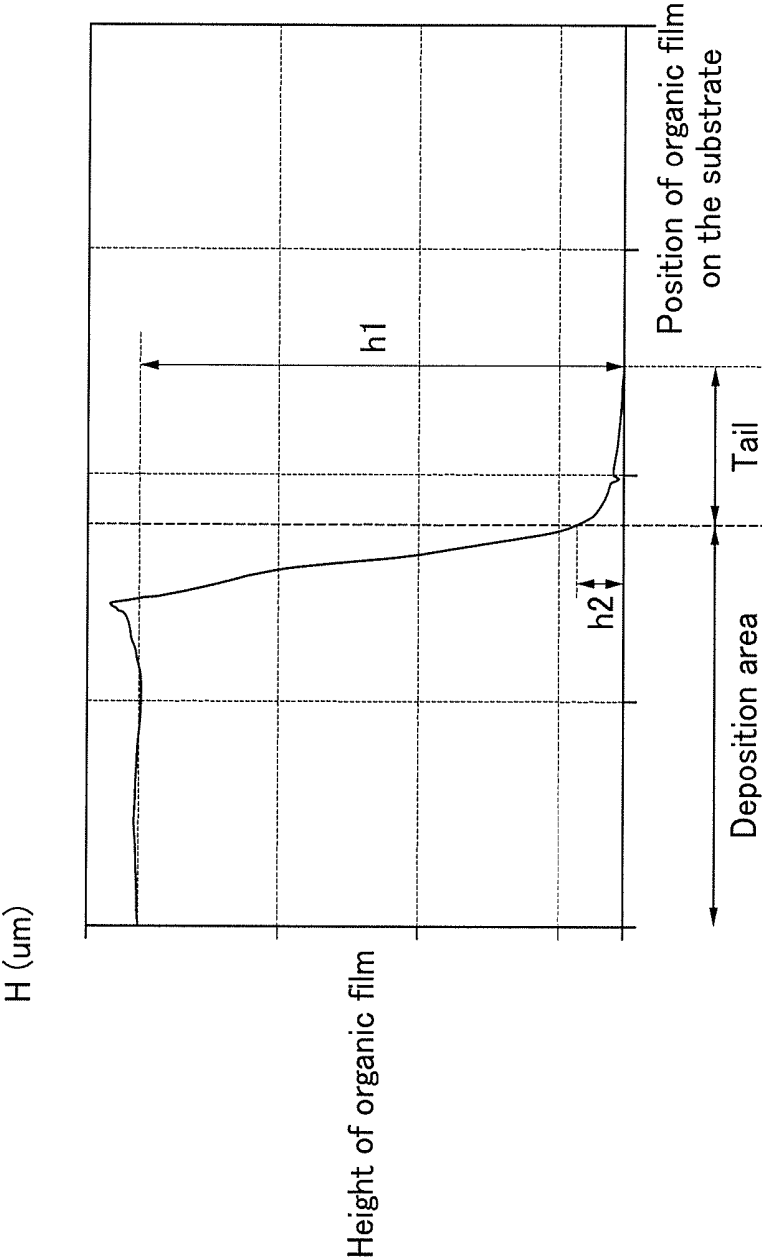

FIG.4

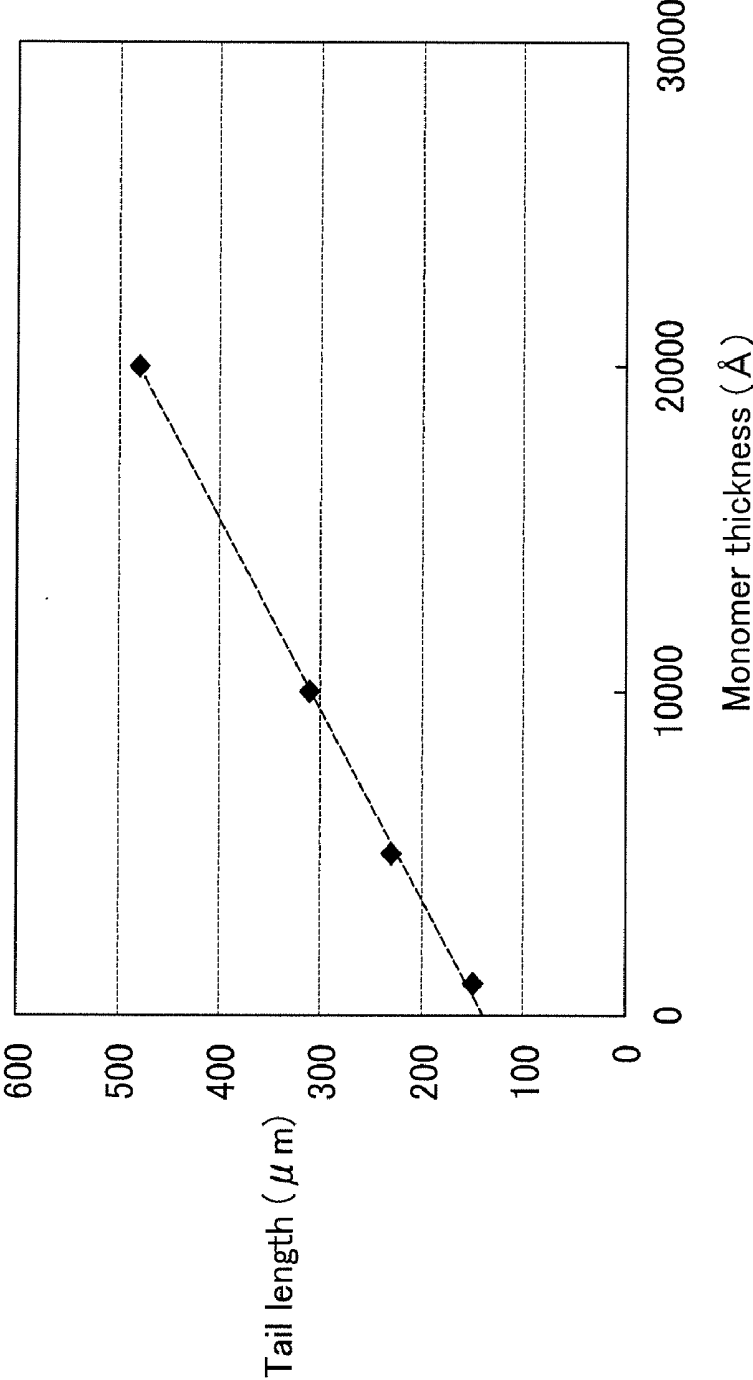

FIG.5

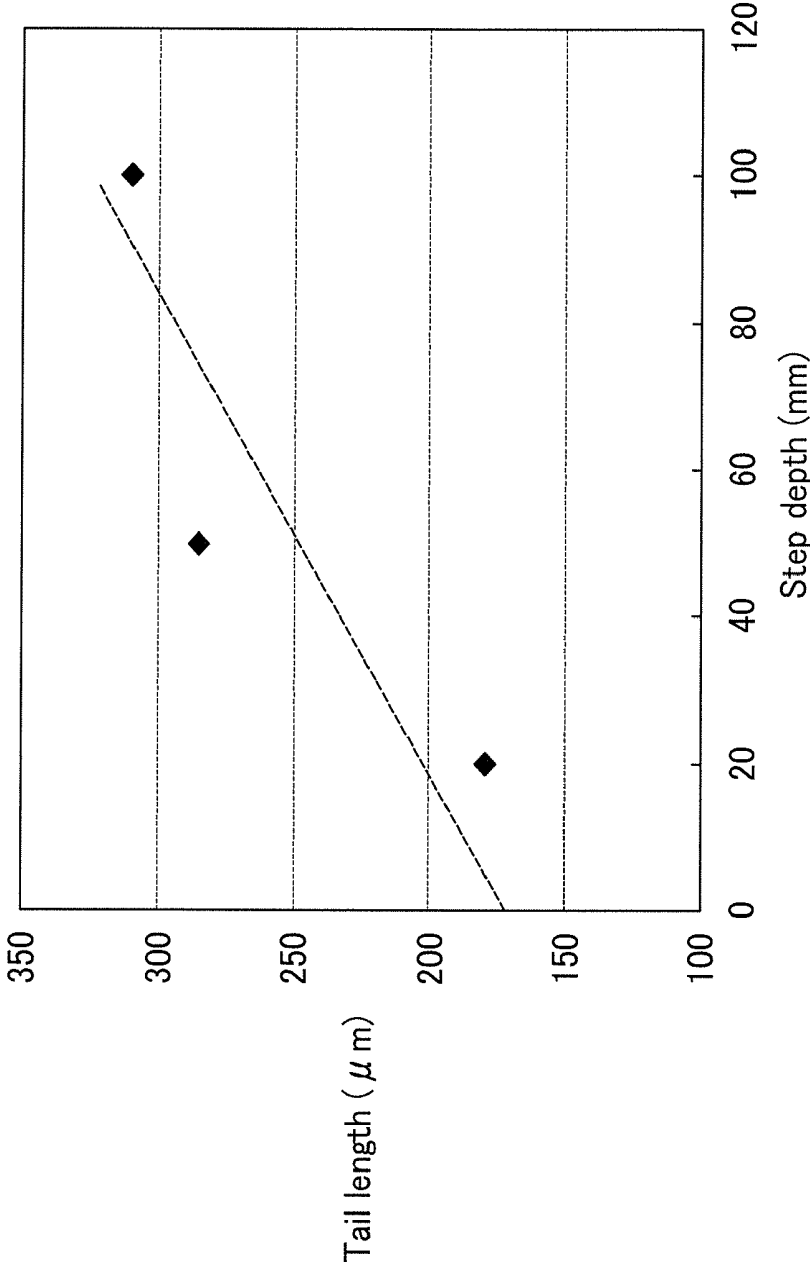

FIG.6

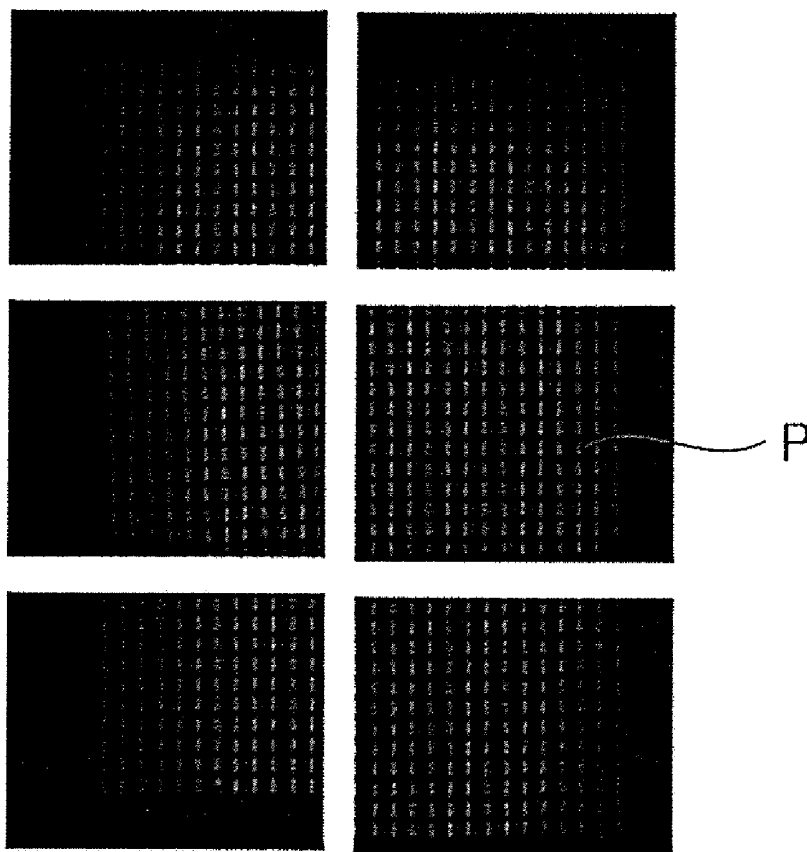
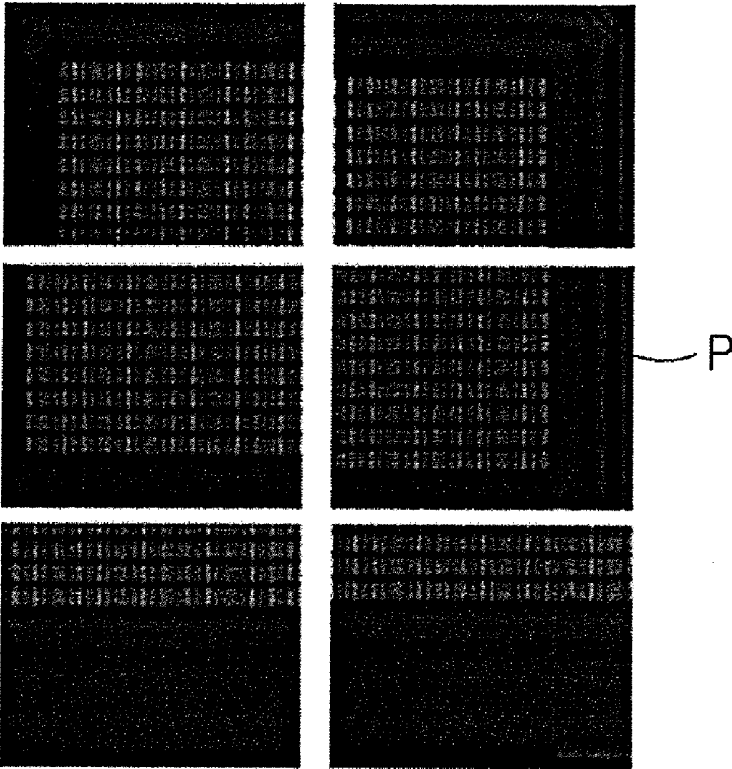

FIG. 7



**ORGANIC LIGHT-EMITTING DIODE
DISPLAY AND MANUFACTURING METHOD
THEREOF**

CROSS-REFERENCE TO RELATED
APPLICATION

[0001] This application claims priority to and the benefit of Korean Patent Application No. 10-2011-0076032 filed in the Korean Intellectual Property Office on Jul. 29, 2011, the entire content of which is incorporated herein by reference.

BACKGROUND

[0002] 1. Field

[0003] The described technology relates generally to an organic light emitting diode (OLED) display, and to a manufacturing method thereof.

[0004] 2. Description of Related Art

[0005] An organic light emitting diode (OLED) display includes a hole injection electrode, an electron injection electrode, and an organic emission layer formed therebetween that emits light as holes injected from an anode and electrons injected from a cathode are recombined to become extinct at the organic light emission layer. The organic light emitting diode (OLED) display device, which has high quality properties such as low power consumption, high luminance, a high reaction speed, and the like, is receiving much attention as a next-generation display device for mobile electronic devices.

[0006] The organic light emitting diode (OLED) display includes an organic light emitting display panel including a display substrate on which thin film transistors and organic light emitting diodes (OLEDs) are formed. The organic light emitting diode includes an anode, a cathode, and an organic emission layer. Holes and electrons are injected from the anode and the cathode, respectively, to form excitons, which make a transition to a ground state, thereby causing the organic light emitting diode to emit light.

[0007] The organic light emitting diode formed with an organic material may have deteriorated performance when exposed to moisture or oxygen, and therefore, an encapsulation technique is used in the organic light emitting display panel to reduce or prevent deterioration due to moisture and oxygen.

[0008] With the thin film encapsulation technique, one or more of inorganic and organic layers are alternately deposited on the organic light emitting diodes formed at the display area of the substrate, thereby covering the display area with a thin film encapsulation layer. With the OLED display having such a thin film encapsulation layer, if the substrate is formed with a flexible film, it can be more easily bent, and is advantageous in forming a slim structure.

[0009] However, when depositing an organic film on the substrate on which the organic light emitting diodes are formed, a liquid monomer can be deposited on the substrate, and can be hardened by using electron beams or ultraviolet (UV) rays. In this instance, the organic film is deposited in a liquid state so spreading over the deposition area set by a mask may occur at an end of the organic film, that is, an edge area of the organic film. When inorganic film is formed without considering the part that is generated due to the spreading phenomenon, the end part of the organic film is not completely sealed by the inorganic film, but is instead exposed. In this case, the organic film allows for a moisture permeation path of external moisture and oxygen to deteriorate perfor-

mance of the organic light emitting diode (OLED) display, and a non-display defect, which is referred to as "dark spots," can occur. When the deposition area of the inorganic film is extended more than needed to prevent the above-noted problem, a "dead space" of the display device is increased.

[0010] The above information disclosed in this Background section is only for enhancement of understanding of the background of the described technology, and therefore, it may contain information that does not form the prior art that is already known in this country to a person of ordinary skill in the art.

SUMMARY

[0011] Embodiments of the present invention provide an organic light emitting diode (OLED) display for preventing permeation of outer moisture and oxygen by applying a thin film encapsulation layer in which an organic film and an inorganic film are stacked, and a manufacturing method thereof.

[0012] Embodiments of the present invention provide an organic light emitting diode (OLED) display for reducing or minimizing a dead space of a display device by checking a deposition area of an inorganic film caused by an organic film thickness and avoiding excess deposition of an inorganic film, and a manufacturing method thereof.

[0013] Embodiments of the present invention provide an organic light emitting diode (OLED) display for reducing or minimizing dark spots and improving an encapsulation lifespan, and a manufacturing method thereof.

[0014] An exemplary embodiment of the present invention provides an organic light emitting diode (OLED) display including a substrate, an organic light emitting diode on the substrate, an organic film configured to cover the organic light emitting diode on the substrate in an organic film deposition area having a first diameter, and an inorganic film configured to cover the organic film on the substrate in an inorganic film deposition area having a second diameter, wherein $L1$ is the first diameter of the organic film deposition area in μm , wherein $L2$ is the second diameter of the inorganic film deposition area in μm , wherein D is a thickness of the organic film in μm , and wherein $L2-L1 \geq 2(171D+150 \mu\text{m})$.

[0015] $(L2-L1)$ may be between 200 μm and 6000 μm , inclusive.

[0016] Another embodiment of the present invention provides a method for manufacturing an organic light emitting diode (OLED) display, the method including

[0017] forming an organic light emitting diode on a side of a substrate, forming an organic film for covering the organic light emitting diode on the side of the substrate and in an organic film deposition area, and forming an inorganic film for covering the organic film on the substrate and in an inorganic film deposition area, wherein $L1$ is a diameter of the organic film deposition area in μm , $L2$ is a diameter of the inorganic film deposition area in μm , D is a thickness of the organic film in μm , and $L2-L1 \geq 2(171D+150 \mu\text{m})$.

[0018] $(L2-L1)$ may be between 200 μm and 6000 μm , inclusive.

[0019] The forming the organic film may include positioning a first mask having a first opening corresponding to the organic light emitting diode, and depositing a material of the organic film through the first opening, wherein forming the inorganic film includes positioning a second mask having a second opening corresponding to the organic film deposition area where the organic film is formed on the substrate, and

depositing a material of the inorganic film through the second opening, wherein the first opening has a step in which a diameter on a rear side of the first mask facing the substrate is greater than a diameter on a surface side of the first mask opposite the rear side, wherein $L1'$ is the diameter of the first opening on the surface side of the first mask in μm , wherein $L2'$ is a diameter of the second opening in μm , wherein A is a height of the step in μm , and wherein $L2'-L1' \geq 2 (1.5214 \times 10^{-3}A + 210 \mu\text{m})$.

[0020] ($L2'-L1'$) may be between 200 μm and 6000 μm , inclusive.

[0021] According to exemplary embodiments of the present invention, the inorganic film stacked on the organic film seals the organic film to efficiently control permeation of outer moisture and oxygen and to reduce or prevent resultant damage to the organic light emitting diode (OLED) display, and improves the encapsulation life-span of the organic light emitting diode.

[0022] Further, according to exemplary embodiments, the deposition area of the inorganic film caused by a thickness of the organic film is checked to prevent undesired deposition of an inorganic film, thereby increasing production efficiency and reducing or minimizing the dead space of the display device.

BRIEF DESCRIPTION OF THE DRAWINGS

[0023] FIG. 1 and FIG. 2 show cross-sectional views corresponding to a method for manufacturing an organic light emitting diode (OLED) display according to an exemplary embodiment of the present invention.

[0024] FIG. 3 shows a graph corresponding to a thickness (or height) of an organic film at a region including an edge of the organic film.

[0025] FIG. 4 shows a graph indicating a correlation between a length of an organic film tail and a thickness of an organic film.

[0026] FIG. 5 shows a graph indicating a correlation between a length of an organic film tail and a height of a step of an organic film mask.

[0027] FIG. 6 shows a photograph of a turned-on organic light emitting diode (OLED) display that was manufactured according to a comparative example in a high temperature and high humidity condition.

[0028] FIG. 7 shows a photograph of a turned-on organic light emitting diode (OLED) display manufactured according to an exemplary embodiment of the present invention in a high temperature and high humidity condition.

DETAILED DESCRIPTION

[0029] An organic light emitting diode (OLED) display according to an embodiment of the present invention and a manufacturing method thereof will be described with reference to the accompanying drawings. However, the present invention is not limited to the exemplary embodiments disclosed hereinafter, but may be implemented in various different forms. The exemplary embodiments herein merely complete the disclosure and fully provide explanation of embodiments of the invention to the ordinarily skilled person in the art. Like reference numerals refer to like elements.

[0030] In the drawings, the thickness of layers, films, panels, regions, etc., are exaggerated for clarity. In the drawings, for understanding and ease of description, the thicknesses of some layers and areas are exaggerated. It will be understood

that when an element such as a layer, film, region, or substrate is referred to as being "on" another element, it can be directly on the other element, or one or more intervening elements may be present.

[0031] In addition, unless explicitly described to the contrary, the word "comprise" and variations thereof, such as "comprises" or "comprising," will be understood to imply the inclusion of stated elements, but not the exclusion of any other elements. Further, throughout the specification, "on" implies being positioned above or below a target element, and does not necessarily imply being positioned on top with respect to the direction of gravity.

[0032] FIG. 1 and FIG. 2 show cross-sectional views corresponding to a method for manufacturing an organic light emitting diode (OLED) display according to an exemplary embodiment of the present invention, and FIG. 3 shows a graph generated by measuring a thickness (or height) of an organic film at an end, or edge region, of the organic film.

[0033] Referring to FIG. 1 and FIG. 2, the organic light emitting diode (OLED) display includes a substrate 10, and includes an organic film 30 and an inorganic film 40 for encapsulating an organic light emitting diode 20 formed on the substrate 10.

[0034] According to the present embodiment, the substrate 10 includes at least one of glass, polymer, and metal, and is made of a light transmissive, light reflective, or light absorptive material. The substrate 10 is flexible. A wire (not shown) and the organic light emitting diode 20 are provided on the substrate 10. The wire transmits a signal to the organic light emitting diode 20 to drive the organic light emitting diode 20. The organic light emitting diode 20 emits light according to the signal transmitted by the wire.

[0035] The organic light emitting diode 20 includes, although not shown in FIGS. 1 and 2, an anode electrode, an organic emission layer, and a cathode electrode, while the organic emission layer further includes organic layers for transmitting carriers of holes or electrons to an emission layer, as well as the emission layer for emitting light. The organic layers, for example, can be a hole injection layer (HIL) and a hole transport layer (HTL) provided between the anode and the emission layer, and can be an electron injection layer (EIL) and an electron transport layer (ETL) provided between the cathode and the emission layer.

[0036] When a voltage (e.g., a predetermined voltage) is applied to the anode and cathode, the holes injected by the anode are moved to the emission layer by passing through the hole transport layer (HTL) configuring the emission layer, and the electrons injected by the cathode electrode are injected to the emission layer by passing through the electron transport layer (ETL). In this instance, the electrons and the holes are recombined in the emission layer to generate excitons, and the excitons are changed to the ground state from the excited state so that fluorescent molecules of the emission layer emit light to form an image. The organic light emitting diode 20 is provided on the substrate 10, and receives the signal from the wire, and displays the image according to the signal. A pixel represents the minimum unit for displaying an image, and the organic light emitting diode (OLED) display displays images by using a plurality of pixels.

[0037] Performance of the organic light emitting diode 20 is deteriorated when reacted with moisture or oxygen. So, to reduce or prevent deterioration, the organic film 30 and the inorganic film 40, which are for shielding and protecting the organic light emitting diode 20 from external factors as a thin

film encapsulation layer, are sequentially stacked on the organic light emitting diode **20**.

[0038] The organic film **30** represents a thin film for preventing permeation of moisture and oxygen by shielding or protecting the organic light emitting diode **20** from the outside (e.g., from external conditions), and for example, the organic film **30** can be made of an organic material, such as epoxy resin or acryl resin, and the organic material may have a thermal hardening or UV hardening property. The organic film **30** is deposited as a liquid on the organic light emitting diode **20** so as to be substantially flattened or smoothed thereon, thereby enabling a spreading phenomenon for flowing over a predetermined deposition area set by the mask at the end of the organic film **30**, that is, the edge area of the organic film **30** (refer to FIGS. 1-3). That is, as shown in FIG. 3, when a deposition height of the organic film **30** in the width direction (i.e., the x-axis direction of FIG. 3) is considered at the end, or edge area, of the organic film **30**, the height is discontinuously changed at a part where the deposition area is stopped, and a part, or area, where the height of the organic film **30** is abruptly reduced is generated, this part or area being called a tail **31** (see FIGS. 1 and 2). According to the present embodiment, the tail **31** is defined to be an edge part, where the height h_2 is substantially below 5% of the average height h_1 of the deposition area of the organic film **30**. A length M of the tail **31** may vary corresponding to the deposition thickness D of the organic film **30**, and the tail **31** length M caused by the thickness D of the organic film **30** checked by experimental results is expressed in Table 1.

TABLE 1

Organic film thickness (Å)	Tail length (μm)
1000	150
5000	230
10000	310
20000	479

[0039] The organic film thickness (D) and the tail length (M) have a relation satisfying Equation 1 (below), which approximates the experimental results of Table 1, and which is depicted in FIG. 4. Here, the unit of M and D is μm.

$$M=171D+138.14 \mu\text{m} \quad \text{Equation 1}$$

[0040] (M : length of tail, D : thickness of organic film, refer to FIGS. 1 and 2)

[0041] The organic film **30** is efficient in relaxing the stress of the organic light emitting diode (OLED) display. However, the organic film might be a moisture permeation path of outer moisture and oxygen. Accordingly, the organic film **30** is covered with the inorganic film **40**. The inorganic film **40** is coated on the organic film **30** to shield the organic film **30** from the outside, and the inorganic film **40** can be used by selecting from a material or metal having refined glass particulates, and inorganic materials, such as, for example, an oxide, nitride, or ceramic.

[0042] The deposition area of the inorganic film **40** is formed to be greater than the deposition area of the organic film **30**, and the inorganic film **40** surrounds the edge (e.g., periphery) of the organic film **30** to seal the organic film **30**. The inorganic film **40** is desirably formed to have a size in consideration of the tail **31** to exceed the deposition area of the organic film **30**. Therefore, in consideration that the inorganic film **40** covers the formation area of the tail **31**, accord-

ing to the present embodiment, a diameter L_2 of the deposition area of the inorganic film **40** is longer by an amount corresponding to the length (M) of the tail **31** and the thickness (D) of the inorganic film **40** from the diameter L_1 of the deposition area of the organic film **30**, which can be written as Equation 2, referring to FIG. 2. Here, N represents a length of the inorganic film **40** that covers the tail **31** of the organic film **30**.

$$L_2 \geq L_1 + 2N, N = 171D + 150 \mu\text{m} \quad \text{Equation 2}$$

$$L_2 - L_1 \geq 2(171D + 150 \mu\text{m}) \quad \text{Equation 2}$$

[0043] When the inorganic film **40** is formed with the relation corresponding to Equation 2, it can cover the organic film **30** when the tail **31** occurs because of deposition of the liquid organic film **30**. That is, when the thickness of the deposited organic film **30** is checked, a range of the deposition area of the corresponding inorganic film **40** is set to allow the inorganic film **40** to cover the organic film **30** and block, or shield, the organic film **30** from the outside. Therefore, the organic light emitting diode (OLED) display can efficiently reduce or control permeation of the external moisture and oxygen.

[0044] Further, according to results achieved through experiments, it is desirable for the difference ($L_2 - L_1$) between the diameter L_2 of the inorganic film deposition area and the diameter L_1 of the organic film deposition area to be between 200 μm and 6000 μm. When the diameter difference ($L_2 - L_1$) of the deposition area is less than 200 μm, the effect of sealing the organic film **30** by the inorganic film **40** is reduced, and when the diameter difference ($L_2 - L_1$) is greater than 6000 μm, more of the inorganic film **40** is deposited than needed, thereby reducing production efficiency.

[0045] The above-described stacking configuration of the organic film **30** and the inorganic film **40** is applicable to embodiments in which the organic film **30** and the inorganic film **40** are repeatedly stacked multiple times in a like manner.

[0046] Referring to FIG. 1 and FIG. 2, a method for manufacturing an organic light emitting diode (OLED) display according to an exemplary embodiment of the present invention will now be described.

[0047] The method for manufacturing an organic light emitting diode (OLED) display includes: forming an organic light emitting diode **20** on a side of the substrate **10**; forming an organic film **30** on the substrate **10** on which the organic light emitting diode **20** is formed to cover the organic light emitting diode **20**; and forming an inorganic film **40** on the substrate **10** to cover the organic film **30**.

[0048] The organic light emitting diode **20** is formed on one side of the substrate **10**, which corresponds to the above description, and will not be described again.

[0049] An organic film **30** is formed on the substrate **10** to cover the organic light emitting diode **20**. When the organic film **30** is formed, a mask (e.g., a predetermined mask) in which a deposition area is set can be used, a first mask **50** including a first opening **51** corresponding to the size and the form of the organic light emitting diode **20** is located on or near the substrate **10** to cover the organic light emitting diode **20**, and an organic film material **30** to be deposited from a deposition source (not shown) is deposited on the organic light emitting diode **20** through the first opening **51**. The material of the organic film **30** is deposited on the organic light emitting diode **20** with a thickness (e.g., a predetermined thickness) D to form the organic film **30** covering the edge of the organic light emitting diode **20**. The thickness D of the

organic film 30 corresponds to the material of the organic light emitting diode 20, the material of the organic film 30, and relevant processes.

[0050] The organic film 30 is deposited as a liquid on the organic light emitting diode 20 so as to be fluently flattened and smoothed, and a tail 31 is generated by the spreading phenomenon at the edge of the organic film 30, as shown in FIG. 1. The tail 31 (e.g., the length M of the tail 31) has the relation of above-described Equation 1 in connection with the thickness D of the organic film 30. The deposited organic film 30 is made of a thermal hardening resin that is hardened by application of heat or ultraviolet light (e.g., light with a wavelength of 200-400 nm), and the hardening resin is hardened by the UV rays, so it causes a chemical reaction when heat is applied during the process, and a crosslink occurs as a result of the chemical reaction to make it substantially insoluble and hardened.

[0051] When the organic film 30 is formed, an inorganic film 40 for covering the organic film 30 is formed on the organic film 30. When the inorganic film 40 is formed, a mask in which the deposition area is set can be used in a like manner of forming the organic film 30, a second mask 60 including a second opening 61 corresponding to the form and the size of the organic film 30 is located on or near the substrate 10 so as to cover the organic film 30, and an inorganic film material 40 to be deposited from the deposition source is deposited on the organic film 30 through the second opening 61. The inorganic film material 40 is deposited on the organic film 30 with a predetermined thickness to form the inorganic film 40 covering the edge of the organic film 30.

[0052] Particularly, the inorganic film 40 is deposited with a diameter that satisfies Equation 2 so as to cover the tail 31, as described above. When the inorganic film 40 is formed with the relation following Equation 2, the organic film 30 can be covered when the tail 31 is generated due to the deposition of the liquid organic film 30. That is, when the thickness D of the deposited organic film 30 is checked, the organic film 30 can be covered from the outside by setting the range of the deposition area of the inorganic film 40. Therefore, the organic light emitting diode (OLED) display can efficiently reduce permeation of the external moisture and oxygen. Further, as described, according to the present embodiment, it is desirable for the difference (L2-L1) between the diameter L2 of the inorganic film deposition area and the diameter L1 of the organic film deposition area to be between 200 μm and 6000 μm.

[0053] In addition, regarding the first mask 50 used to form the organic film 30, the first opening 51 can be formed with two stages, and in this instance, the first opening 51 has a two step configuration including a step 53 in which the diameter of a rear side (i.e., the side that faces the substrate) of the first mask 50 facing the substrate 10 is greater than the diameter on the surface side (i.e., the side opposite to the rear side and facing away from the substrate). When the first mask 50 is configured with two stages, a problem of protrusions and depressions at the end of the tail 31, or attachment of particles thereto, can be reduced or prevented when the organic material 30 is deposited as a liquid, and a tail 31 is generated because of the spreading phenomenon.

[0054] According to the present embodiment, the length of the organic film tail 31 is variable corresponding to the height A of the step 53 in the two-stage configuration, and FIG. 5 shows a graph depicting a correlation of the length M of the organic film tail 31 and the height A of the step 53 of the

organic film mask 50 when the organic film 30 is deposited with the thickness (or height) D of 5000 Å. An approximate relationship between the height (A) of the step 53 of the organic film mask 50 and the length (M) of the organic film tail 31, as found through experiments, is expressed in Equation 3 (the unit of variables A and M being μm).

$$M=1.5214 \times 10^{-3} A + 171.79 \text{ } \mu\text{m} \quad \text{Equation 3}$$

[0055] When the inorganic film 40 is formed by considering the length M of the tail 31, the diameter L2 of the deposition area of the inorganic film 40 must be formed to be longer than the diameter L1 of the deposition area of the organic film 30 by at least the length (M) of the tail 31. The second opening 61 of the second mask 60 is formed to have a size for enabling covering of the organic film 30 and corresponding to the deposition area of the organic film 30, so the diameter (L2') of the second opening 61 of the second mask 60 corresponds to the diameter L2 of the deposition area of the inorganic film 40. In a like manner, the diameter (the surface side L1') of the first opening 51 of the first mask 50 corresponds to the diameter L1 of the deposition area of the organic film 30. This is expressed in Equation 4 with reference to FIG. 1 and FIG. 2.

$$L2' \geq L1' + 2N, N = 1.5214 \times 10^{-3} A + 210 \text{ } \mu\text{m}$$

$$L2' - L1' \geq 2(1.5214 \times 10^{-3} A + 210 \text{ } \mu\text{m}) \quad \text{Equation 4}$$

[0056] (L1': the diameter on the surface side of the first opening, L2': the diameter of the second opening, A: the height of the step, and N: the length of the inorganic film covering the tail of the organic film, wherein the unit for variables L1, L2', A, and N is μm)

[0057] When the inorganic film 40 is formed following Equation 4, the organic film 30 can be covered when the tail 31 occurs because of deposition of the liquid organic film 30.

Experimental Example

[0058] An effect of an organic light emitting diode (OLED) display according to an exemplary embodiment of the present invention will be described by comparing an organic light emitting diode (OLED) display according to a comparative example and an organic light emitting diode (OLED) display according to the exemplary embodiment of the present invention.

[0059] FIG. 6 shows a photograph of an organic light emitting diode (OLED) display that is manufactured, according to a comparative example, in a high temperature and high humidity condition, the organic light emitting diode (OLED) display being turned on, and FIG. 7 shows a photograph of an organic light emitting diode (OLED) display that is manufactured according to an exemplary embodiment of the present invention in a high temperature and high humidity condition, the organic light emitting diode (OLED) display being turned on.

[0060] In the comparative example of FIG. 6, the thickness (D) of the organic film is set to be 5000 Å for deposition, and the organic light emitting diode (OLED) display, which is manufactured by setting both lengths of the diameter L2 of the deposition area of the inorganic film 40 to be greater than the diameter L1 of the deposition area of the organic film 30 by 200 μm, is exposed for 295 hours in a high-temperature and high-humidity condition. When the organic film is set to have the thickness (D) of 5000 Å and is deposited in a like manner as the comparative example, the tail is formed to have

the length of 230 μm , and the inorganic film cannot fully cover the tail because the diameter L2 of the deposition area of the inorganic film 40 is less than the sum of the diameter L1 of the deposition area of the organic film 30 and the lengths of the tails at both ends (i.e., it fails to satisfy Equation 2) in the comparative example. In this case, moisture and oxygen are permeated to the edge of the organic light emitting diode (OLED) display so the pixels (P) on the edge fail to emit clear light, differing from the pixels in the center part as shown in FIG. 6.

[0061] In the exemplary embodiment of the present invention depicted in FIG. 7, the organic film 30 is set to have the thickness (D) of 5000 \AA , and is then deposited, and the organic light emitting diode (OLED) display, which is manufactured by setting the length of the diameter L2 of the deposition area of the inorganic film 40 to be greater than the diameter L1 of the deposition area of the organic film 30 by 300 μm , respectively, is exposed for 800 hours in a high-temperature and high-humidity condition. In the present exemplary embodiment, the diameter L2 of the deposition area of the inorganic film 40 is greater than the sum of the lengths (M) of the tails 31 at both ends and the diameter L1 of the deposition area of the organic film 30 (i.e., it satisfies Equation 2), so the inorganic film 40 can fully cover the tail 31 of the organic film 30. In this case, even though the organic light emitting diode (OLED) display is exposed for a long time (e.g., over 500 hours) in the high temperature and high humidity condition, the pixels (P) on the edge emit clear light in a manner similar to that of the pixels in the center, as shown in FIG. 7.

[0062] While this disclosure has been described in connection with what is presently considered to be practical exemplary embodiments, it is to be understood that the invention is not limited to the disclosed embodiments, but, on the contrary, is intended to cover various modifications and equivalent arrangements included within the spirit and scope of the appended claims, and their equivalents.

What is claimed is:

1. An organic light emitting diode (OLED) display comprising:

a substrate;

an organic light emitting diode on the substrate;

an organic film configured to cover the organic light emitting diode on the substrate in an organic film deposition area having a first diameter; and

an inorganic film configured to cover the organic film on the substrate in an inorganic film deposition area having a second diameter, wherein L1 is the first diameter of the organic film deposition area in μm , wherein L2 is the second diameter of the inorganic film deposition area in μm , wherein D is a thickness of the organic film in μm , and wherein $L2-L1 \geq 2(171D+150 \mu\text{m})$.

2. The organic light emitting diode display of claim 1, wherein $200 \mu\text{m} \leq (L2-L1) \leq 6000 \mu\text{m}$.

3. A method for manufacturing an organic light emitting diode (OLED) display, the method comprising:

forming an organic light emitting diode on a side of a substrate;

forming an organic film for covering the organic light emitting diode on the side of the substrate and in an organic film deposition area; and

forming an inorganic film for covering the organic film on the substrate and in an inorganic film deposition area, wherein L1 is a diameter of the organic film deposition area in μm , L2 is a diameter of the inorganic film deposition area in μm , D is a thickness of the organic film in μm , and $L2-L1 \geq 2(171D+150 \mu\text{m})$.

4. The method of claim 3, wherein $200 \mu\text{m} \leq (L2-L1) \leq 6000 \mu\text{m}$.

5. The method of claim 3, wherein forming the organic film comprises: positioning a first mask having a first opening corresponding to the organic light emitting diode; and depositing a material of the organic film through the first opening,

wherein forming the inorganic film comprises: positioning a second mask having a second opening corresponding to the organic film deposition area where the organic film is formed on the substrate; and depositing a material of the inorganic film through the second opening,

wherein the first opening has a step in which a diameter on a rear side of the first mask facing the substrate is greater than a diameter on a surface side of the first mask opposite the rear side,

wherein L1' is the diameter of the first opening on the surface side of the first mask in μm ,

wherein L2' is a diameter of the second opening in μm ,

wherein A is a height of the step in μm , and

wherein $L2'-L1' \geq 2(1.5214 \times 10^{-3}A+210 \mu\text{m})$.

6. The method of claim 5, wherein $200 \mu\text{m} \leq (L2'-L1') \leq 6000 \mu\text{m}$.

* * * * *

专利名称(译)	有机发光二极管显示器及其制造方法		
公开(公告)号	US20130026533A1	公开(公告)日	2013-01-31
申请号	US13/439746	申请日	2012-04-04
[标]申请(专利权)人(译)	LEE JAE HO		
申请(专利权)人(译)	LEE, JAE-HO		
当前申请(专利权)人(译)	三星DISPLAY CO., LTD.		
[标]发明人	LEE JAE HO		
发明人	LEE, JAE-HO		
IPC分类号	H01L51/52 H01L51/56		
CPC分类号	H01L51/5253 H01L2251/558 H01L2251/55 H01L51/5256		
优先权	1020110076032 2011-07-29 KR		
其他公开文献	US8664649		
外部链接	Espacenet USPTO		

摘要(译)

一种有机发光二极管显示器，包括：基板；基板上的有机发光二极管；有机膜，被配置为在具有第一直径的有机膜沉积区域中覆盖基板上的有机发光二极管；以及无机膜，被配置为在具有第二直径的无机膜沉积区域中覆盖基板上的有机膜，其中L1是有机膜沉积区域的第一直径（ μm ），其中L2是无机膜沉积区域的第二直径（ μm ），其中D“有机膜的厚度”是 μm ，并且其中 $L2-L1 \geq 2(171D + 150\mu\text{m})$ 。

